

Cat.5e 24Port Vertical Patch Panel (FTP) / Dual Type

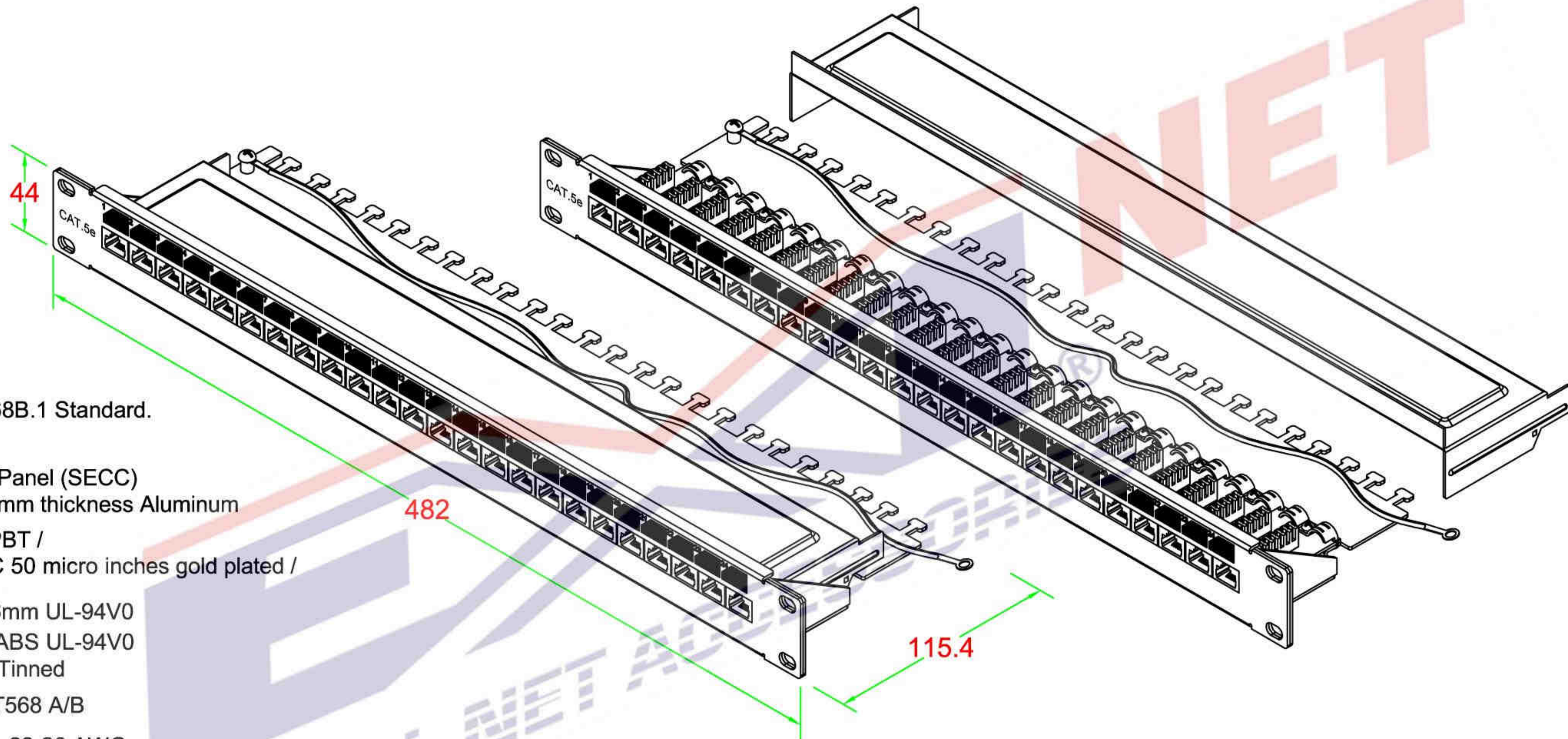

Performance :
Meets Cat.5e EIA/TIA 568B.1 Standard.

Materials :

Bottom Panel : Metallic Panel (SECC)
Upper Panel Cover : 1.2mm thickness Aluminum

RJ-45 Jack : Housing-PBT /
FTP 8P8C 50 micro inches gold plated /

PCB : FR-4 / 1.6mm UL-94V0
IDC Body : Fireproof ABS UL-94V0
IDC Pin : Bronze & Tinned

Label Color Code : T568 A/B

IDC Description : For 22-26 AWG.
For 110 or Krone punch-down Tool

Electrical Specifications:

Insulation Resistance : 500M ohms (min.)
Contact Resistance : 20m ohms (max.)
Current Rating : 1.5 Amps .
DC Resistance : 0.1 ohm (max.)
Withstanding Voltage : 1000 VAC RMS @ 60Hz / 1 min.

Mechanical Specifications:

IDC Punch Down Cycle : Over 25 Cycles (min.)
RJ-45 Jack Insertion Cycle : Over 2000 Cycles (min.)
Operation Temperature : -40 ~ +70 degree / C

DRAW NO:		ITEM NO:	PATCHP24PHZF-EX
	APPR	CUSTOMER:	
UNIT: m/m	CHECK	DATE:	
SCALE:	DESIGN	TOLERANCE:	· ± 1 · X ± 0.2 · XX ± 0.15